



DRC

DIN Rail Mounted Proportional Valve Controller

The DRC is a compact, DIN-rail mounted controller for use with proportional solenoid valves. The DRC provides current to a valve coil in proportion to a command signal. Bright LED indicators on the front of the unit provide an overview of the operating status. Setup is accomplished through a convenient hand held interface or a PC. There are no jumpers or tiny pots to set. Once configured, the settings are stored in permanent memory within the unit. The DRC enclosure features convenient DIN-rail mounting and removable terminal blocks.

- Easily configured using WhiteOak Terminal software or our hand held interface
- LED indication of power, output current and fault status
- Compact DIN-rail mount housing
- Multiple modes for single and dual coil applications
- Input options include -10V to 10V, 0 to 20mA
- Programmable enable input
- All input and output limits are independently adjustable
- Adjustable current limited output with short circuit protection
- +10 and -10 volt references for potentiometer/joystick controls
- Adjustable ramp up and ramp down rates
- Selectable dither frequency up to 1000 Hz
- Microprocessor controlled for consistent, reliable performance



Operating Specifications:

Supply Voltage	9 to 32VDC
Supply Current	I _{SOL} + 50mA
Output Current	DRC-x06: 600mA MAX. DRC-x12: 1.2A MAX. DRC-x25: 2.5A MAX.
Solenoid Resistance	2Ω MIN.
Reference Voltages	+10V, -10V @ 20mA (DRC-Vxx versions only)
Dither Settings	30, 50, 75, 100, 125, 150, 175, 200, 225, 250, 275, 300, 1000 Hz
Analog Input Range	DRC-Vxx: -10V to 10V DRC-Axx: 0 to 20mA
Analog Input Impedance	DRC-Vxx: 38kΩ DRC-Axx: 250Ω
Operating Temperature Range	-20° to 70° C
Enclosure	Polyamide
Dimensions	Inch: 0.69 W x 4.50 H x 4.30 D mm: 17.5 W x 114.5 H x 109.4 D

WARRANTY INFORMATION, PERFORMANCE ASSURANCE, AND APPLICATION LIMITATIONS

Limited Warranty

WhiteOak Controls, Inc. warrants its products free from defects in material, workmanship, and design for a period of one year after installation, provided the installation date is less than one year after manufacture. In no instance is there any warranty of fitness for a particular use and WhiteOak Controls, Inc. cannot and does not accept responsibility of any type for any of its products that have been subjected to improper installation, improper application, negligence, tampering, or abuse, or which have been repaired or altered outside of the WhiteOak Controls factory. WhiteOak Controls' liability under this warranty shall extend only to replacement or correction, f.o.b. our factory, of any defective part or product determined by inspection as not conforming to this warranty. We make no other warranties, expressed or implied, and are not responsible for any consequential damages resulting from use by any buyer or user, our liability being limited to the value of product sold or obligation to replace a defective part.

Performance Assurance

All WhiteOak Controls products are individually tested at the factory to perform as indicated in all applicable sales and technical documentation. However, assurance of suitability of all WhiteOak Controls products in the buyer's application is the responsibility of the buyer. Such assurance would typically include the manufacture of a prototype followed by a test or qualification program on the part of the buyer.

Application Limitations

WhiteOak Controls, Inc. designs and manufactures its products specifically for use in commercial, industrial and mobile control applications and WhiteOak Controls' products are only warranted for this type of use. WhiteOak Controls' distributors are not authorized to approve the use of any WhiteOak Controls product in any of the following applications:

- Any product that comes under the Federal Highway Safety Act, namely steering or braking systems for passenger-carrying vehicles or on-highway trucks.
- Aircraft or space vehicles.
- Ordnance equipment.
- Any end product that, when sold, comes under the U.S. Nuclear Regulatory Commission rules and regulations.

Specific written approval for any application of WhiteOak Controls products in any of the above named applications should be obtained from WhiteOak Controls, Inc. Consultation with WhiteOak Controls distributors or factory engineers is advised in unusual situations where applicability is questionable.



DRC

DIN Rail Mounted Proportional Valve Controller

Physical Description

The DRC is shown at the right. There are five indicator lamps labeled PWR and OUT1 through OUT4 (for the four channel controller). The PWR lamp will light green whenever power is applied to the unit and is within the specified voltage range. Under normal operation the OUTx lights will provide an indication of the current being supplied to the solenoid output for a given channel. The lights will be yellow and the brightness will vary with the output current. In the case of a fault the light will flash red with a flash code corresponding to the type of fault for that channel.

Communication with the DRC takes place through the USB port. The port allows for configuration and monitoring of the operating parameters.

Note: When connected to a PC, the DR controller will be recognized as a USB device with or without power applied to the controller. However, to configure the controller it must be powered.



User Interface

The DRC has a number of internal settings which allow each unit to be configured for the application in which it is used. These settings are accessed with a PC running Windows based WhiteOak Terminal software or with the WhiteOak Hand Held Interface

WhiteOak Terminal provides a convenient interface to the DRC. The program gives the user the ability to view and make changes to the configuration. It also allows the user to store complete configurations in files on the PC. These files can then be recalled to program new units or update existing ones.

The hand held interface is a stand-alone option. Because it is fully self-contained, the programmer, cable and adapter are all that is required. This is a good alternative for field installations where a PC might not be convenient.

Configuration

All interface operations are accomplished with the use of 4 buttons. The buttons are Lock, Unlock, Up, and Down. The hand held interface represents these in graphical form as padlocks and arrows. The same symbols are used on the buttons in WhiteOak Terminal and can be activated with the mouse. The program also recognizes short-cut keys. The keys used are '/'(lock), '*'(unlock), '+'(up), and '-'(down).

The data displays for both methods are very similar. The hand held interface has a two-line LCD display. The display is represented graphically in WhiteOak Terminal.

The up and down arrows are used to navigate through the parameter list. When either button is pressed the display will be updated with the next parameter in the list. The parameter name will appear on the first line and the associated setting will appear on the second line. The list is accessed in a circular fashion, stepping down from the last parameter to the first and vice-versa.

There are three types of parameters in the list: fixed; monitor; and variable. Fixed parameters are used to show things such as the module's firmware version number. Fixed parameters do not change. Monitor parameters display things such as output current or system voltage. These parameters are constantly updated when the module is functioning. Variable parameters are those which can be changed by the user in order to configure the module. Examples of this type are operating mode and maximum output current. For convenience, some parameters combine variable and monitor types on one line. This allows the user to set a variable according to the current monitor value.

To change the setting of a variable parameter, the user must press the unlock button to place the system in edit mode. While in edit mode the display will show an asterisk (*) at the beginning of the second line. In edit mode the up and down buttons are used to change the value of the parameter. For parameters which contain both variable and monitor data, the monitor data is shown surrounded by square brackets. Pressing the unlock button again while in edit mode will immediately load the current monitor value into the variable. Once the desired setting is displayed, pressing the lock button will save the parameter and end edit mode.

Parameter List

The following table outlines the parameter list for the DRC. Along with the name of the parameter, the table lists the limits and units for each item.

Parameter	Limits	Units
DRCx-xxx		Version #
C1 MODE	See Mode Description	Mode #
C1 MIN INPUT	-10 to +10.0 (0 to 20.0)	V (mA)
C1 MAX INPUT	-10 to +10.0 (0 to 20.0)	V (mA)
C1 MIN OUTPUT	0 to 600 ¹	mA
C1 MAX OUTPUT	0 to 600 ¹	mA
C1 RAMP UP	0.0 to 120.0	Seconds
C1 RAMP DOWN	0.0 to 120.0	Seconds
Previous 7 parameters repeated for all channels ²		
DITHER FREQ.	30 to 1000	Hz.
C1 COMMAND INPUT		V (mA)
C1 OUTPUT CURRENT		mA
Previous 2 parameters repeated for all channels ²		
SUPPLY VOLTAGE		Volts
FAULT STATUS		Fault

¹0 to 1.2 A for **-12A** version, 0 to 2.5 A for **-25A** version

²Parameters shown starting with C1 are repeated for each remaining channel and are displayed as C2 to C4

DRCx-xxx - This is the title parameter. The model number of the unit and the firmware version are displayed. The title parameter is fixed.

Cx MODE – There are up to four modes of operation for the DRC controller. The basic two modes, using channel 1 as an example, are as follows:

1 IN1 NO ENBL - Output is controlled by the corresponding input. Enable is not used.



DRC

DIN Rail Mounted Proportional Valve Controller

2 IN1 USE ENBL – Output is controlled by the corresponding input. Enable is used.

Channels 2 and 4 have two additional modes. Using channel 2 as an example, the modes are as follows:

3 IN1 NO ENBL - Output is controlled by the previous channel's input. Enable is not used.

4 IN1 USE ENBL - Output is controlled by the previous channel's input. Enable is used.

These additional modes allow channels 2 and 4 to be coupled to channels 1 and 3 respectively for dual coil, 3 position valves. As an example, to drive a directional proportional valve with outputs 1 and 2, C1 Mode should be set to mode 1 or 2 and C2 Mode should be set to mode 3 or 4. The input range should then be set such that they do not overlap. Further examples are found in the applications section.

Cx MIN INPUT - The Min Input parameter is used to set the command level which corresponds to the minimum output. The Min Input can be greater than the Max Input if an inverted input/output profile is desired. See the Applications section for examples. The value shown in square brackets is the current analog command value for this channel. The Min Input parameter is a combination variable/monitor type.

Cx MAX INPUT - The Max Input parameter is used to set the command level which corresponds to the minimum output. The Max Input can be less than the Min Input if an inverted input/output profile is desired. See the Applications section for examples. The value shown in square brackets is the current analog command value for this channel. The Max Input parameter is a combination variable/monitor type.

Cx MIN OUTPUT - The Min Output parameter represents the minimum current of the output. This is similar to the dead band setting on amplifiers with combined input/output settings. The Min Output parameter must always be less than the Max Output parameter. The value displayed represents the current in milliamps (amps for -12A,-25A). The value shown in square brackets is the real time output current for this channel. The Minimum Output parameter is a combination variable/monitor type.

Cx MAX OUTPUT - The Max Output parameter represents the maximum current of the output. This is similar to the gain setting on amplifiers with combined input/output settings. The Max Output parameter must always be greater than the Min Output parameter. The value displayed represents the current in milliamps (amps for -12A,-25A). The value shown in square brackets is the real time output current for this channel. The Maximum Output parameter is a combination variable/monitor type.

Cx RAMP UP/DOWN – Ramp Up and Ramp Down are used to limit the rate of change of the input command signal, and therefore the ramp time of the output. **The Ramp settings represent the amount of time in seconds required to ramp through the full input range.** When the input command is increasing, the Ramp Up setting is used. When the input command is decreasing, the Ramp Down setting is used. The Ramp Up/Ramp Down parameters are variable.

DITHER FREQ. - The Dither Frequency parameter has 13 options for dither control. The choices are 30, 50, 75, 100, 125, 150, 175, 200, 225, 250, 275, 300, and 1000 Hz. Dither control provides low frequency modulation which is required in many proportional valve applications. In the DRC controller the Dither Frequency is equal to the PWM frequency. The Dither Frequency parameter is variable.

Cx COMMAND INPUT – Command Input displays the real time input being supplied to this channel. The Command Input parameter is a monitor type.

Cx OUTPUT CURRENT - Output Current displays the nominal current being supplied to the output. The Output Current parameter is a monitor type.

SUPPLY VOLTAGE - The Supply Voltage parameter displays the module's power supply voltage. This value is included as an aid to troubleshooting. The Supply Voltage parameter is a monitor type.

FAULT STATUS - The Fault Status parameter displays the current fault code or codes when one or more faults exist. The two faults are Open Output and Output Short. The Fault Status parameter is a monitor type and will scroll through the faults if more than one exist. In addition to the on-screen fault status, the STATUS light will flash red indicating a problem. The light will flash a number of times periodically corresponding to the type of fault with 2 flashes for Open Output and 3 flashes for Output Short.



DRC

DIN Rail Mounted Proportional Valve Controller

Ordering Information

The following is a break down of the DRC part numbering system:

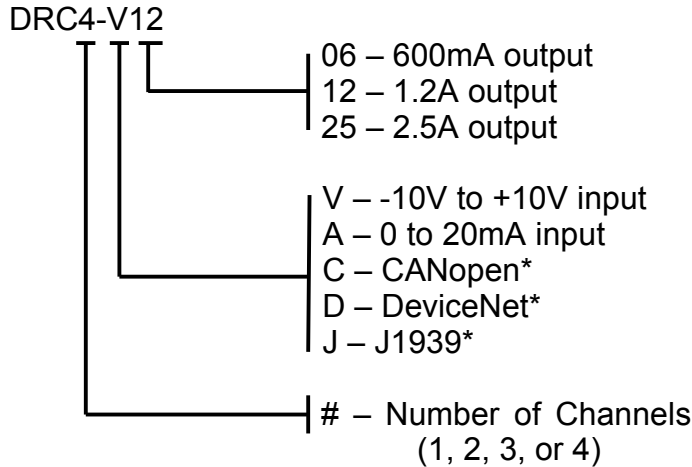

*Future product

Wiring

Terminal functions are listed in the table below. Following the table are application examples for various modes of operation.

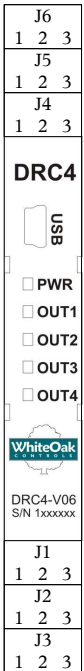

Terminal	Function
J1-1	+V Supply
J1-2	Supply Common
J1-3	Enable Input
J2-1	Output Ch. 1
J2-2	Common
J2-3	Output Ch. 2
J3-1	Output Ch. 3
J3-2	Common
J3-3	Output Ch. 4
J4-1	-10V Reference
J4-2	Common
J4-3	+10V Reference
J5-1	Command Input Ch. 1
J5-2	Common
J5-3	Command Input Ch. 2
J6-1	Command Input Ch. 3
J6-2	Common
J6-3	CCommand Input Ch. 4

Applications

Single Solenoid Joystick Control (DRC1-Vxx)

The DRC can be controlled with a joystick or potentiometer as shown. The recommended potentiometer value is 10kΩ. Mode 1 may be used rather than Mode 2 if the enable is not used. Dither and Output settings will vary depending on the valve and application.

Schematic:

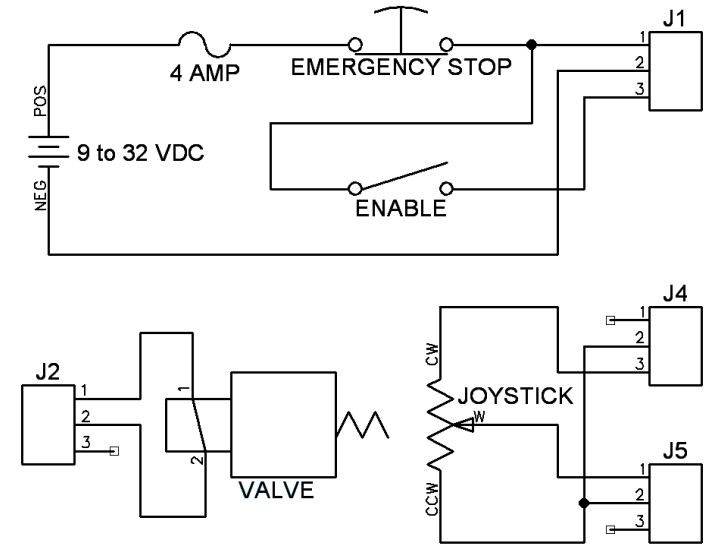

Example Settings:

Parameter	Value
C1 Mode	2 IN1 USE ENBL
C1 MIN INPUT	0.2 V
C1 MAX INPUT	10.0 V
C1 MIN OUTPUT	5 mA
C1 MAX OUTPUT	600 mA
C1 RAMP UP	1 S
C1 RAMP DOWN	1 S
DITHER	150 Hz.

Input/Output Diagram

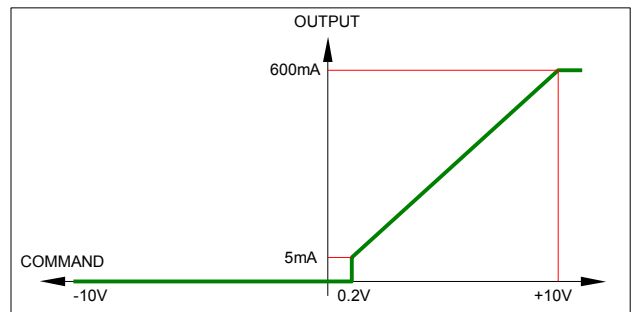

Double Solenoid Joystick(DRC2-Vxx)

The DRC can be setup to drive a double solenoid valve using one command as shown in the following diagram. If enable is not used, C1 Mode should be set to 1 and C2 Mode to 3. The minimum and maximum input parameters for the two channels must be set such that both outputs will not be active with the same input signal. The settings do not have to be the same or mirrored between the two channels as shown in the example though in many cases they will be. Dither and Output settings will vary depending on the valve and application.

Schematic:

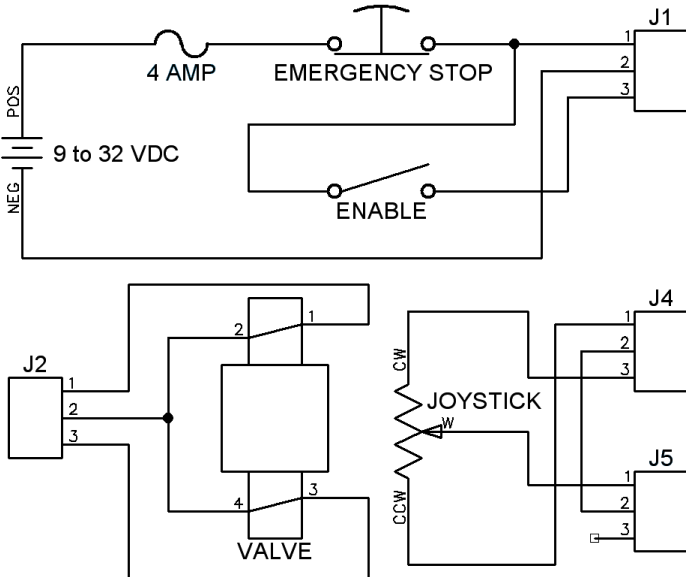

Input/Output Diagram

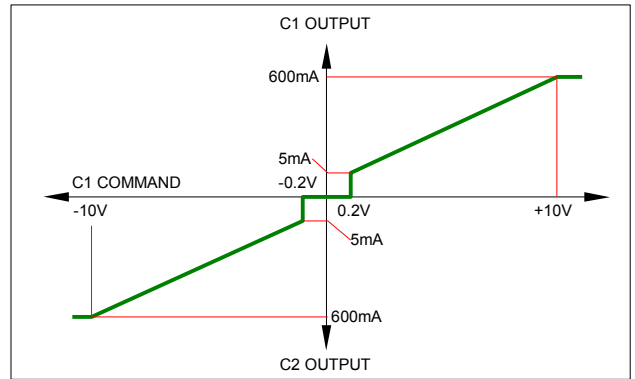

Example Settings:

Parameter	Value
C1 MODE	2 IN1 USE ENBL
C1 MIN INPUT	0.2 V
C1 MAX INPUT	10.0 V
C1 MIN OUTPUT	5 mA
C1 MAX OUTPUT	600 mA
C1 RAMP UP	1 S
C1 RAMP DOWN	1 S
C2 Mode	4 IN1 USE ENBL
C2 MIN INPUT	-0.2 V
C2 MAX INPUT	-10.0 V
C2 MIN OUTPUT	5 mA
C2 MAX OUTPUT	600 mA
C2 RAMP UP	1 S
C2 RAMP DOWN	1 S
DITHER	150 Hz.



DRC

DIN Rail Mounted Proportional Valve Controller

Double/Single/Single Solenoid (DRC4-Vxx)

The following example shows a DRC setup to drive a double solenoid valve and 2 single solenoid valves using three joysticks for command inputs. Dither and Output settings will vary depending on the valves and the application.

Schematic:

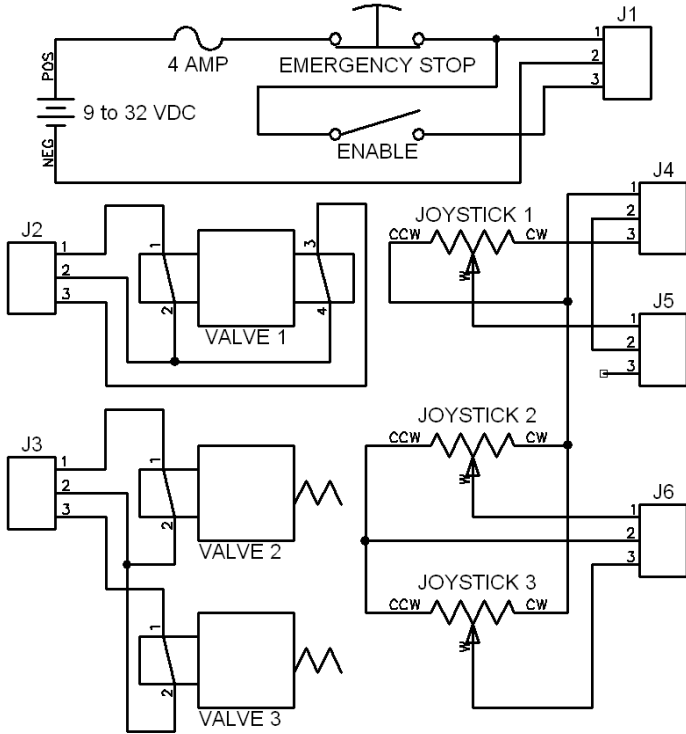

Example Settings:

Parameter	Value
C1 MODE	2 IN1 USE ENBL
C1 MIN INPUT	0.2 V
C1 MAX INPUT	10.0 V
C1 MIN OUTPUT	5 mA
C1 MAX OUTPUT	600 mA
C1 RAMP UP	1 S
C1 RAMP DOWN	1 S
C2 Mode	4 IN1 USE ENBL
C2 MIN INPUT	-0.2 V
C2 MAX INPUT	-10.0 V
C2 MIN OUTPUT	5 mA
C2 MAX OUTPUT	600 mA
C2 RAMP UP	1 S
C2 RAMP DOWN	1 S
C3 Mode	2 IN1 USE ENBL
C3 MIN INPUT	0.2 V
C3 MAX INPUT	10.0 V
C3 MIN OUTPUT	5 mA
C3 MAX OUTPUT	600 mA
C3 RAMP UP	1 S
C3 RAMP DOWN	1 S
C4 Mode	2 IN1 USE ENBL
C4 MIN INPUT	0.2 V
C4 MAX INPUT	10.0 V
C4 MIN OUTPUT	5 mA
C4 MAX OUTPUT	600 mA
C4 RAMP UP	1 S
C4 RAMP DOWN	1 S
DITHER	150 Hz.