



MVP

Digital Proportional Valve Controller Plug

The MVP is a compact, inline controller for use with proportional solenoid valves. The MVP provides current to a valve coil in proportion to an input signal. Bright LED indicators on the top of the unit provide an overview of the operating status. Setup is accomplished through a convenient hand held interface or portable computer. There is no cover to remove and no tiny pots to set. Once configured, the settings are stored in permanent memory within the unit. The MVP comes pre-wired with standard or custom lengths of industrial grade cable. The MVP is housed in a rugged, low-profile 18mm DIN connector body.

- Easily configured using WhiteOak Terminal software or our hand held interface
- LED indication of Status and Output Current
- Permanently sealed, standard DIN 43650 Form A connector body
- Selectable dither frequency up to 300 Hz
- Adjustable current limited output with short circuit protection
- 5 volt reference for potentiometer/joystick controls
- Multiple modes for analog or 2-speed control
- Programmable enable input
- All input and output limits are independently adjustable
- Adjustable ramp up and ramp down times
- Pre-wired 18 AWG PVC cable
- Microprocessor controlled for consistent, reliable performance



Operating Specifications:

Supply Voltage	9 to 28VDC
Supply Current	$I_{SOI} + 20mA$
Output Current	-06A: 600mA MAX. -12A: 1.2A MAX. -25A: 2.5A MAX.
Solenoid Resistance	2Ω MIN.
Reference Voltages	+5V @ 2mA
Dither Settings	Off, 30, 33, 38, 43, 50, 60, 75, 100, 150, 300 Hz
Analog Input Range	-C1V: 0 to 10V -C2A: 0 to 20mA
Analog Input Impedance	20kΩ
Operating Temperature Range	-20° to 70° C
Enclosure	Glass filled Nylon

WARRANTY INFORMATION, PERFORMANCE ASSURANCE, AND APPLICATION LIMITATIONS

Limited Warranty

WhiteOak Controls, Inc. warrants its products free from defects in material, workmanship, and design for a period of one year after installation, provided the installation date is less than one year after manufacture. In no instance is there any warranty of fitness for a particular use and WhiteOak Controls, Inc. cannot and does not accept responsibility of any type for any of its products that have been subjected to improper installation, improper application, negligence, tampering, or abuse, or which have been repaired or altered outside of the WhiteOak Controls factory. WhiteOak Controls' liability under this warranty shall extend only to replacement or correction, f.o.b. our factory, of any defective part or product determined by inspection as not conforming to this warranty. We make no other warranties, expressed or implied, and are not responsible for any consequential damages resulting from use by any buyer or user, our liability being limited to the value of product sold or obligation to replace a defective part.

Performance Assurance

All WhiteOak Controls products are individually tested at the factory to perform as indicated in all applicable sales and technical documentation. However, assurance of suitability of all WhiteOak Controls products in the buyer's application is the responsibility of the buyer. Such assurance would typically include the manufacture of a prototype followed by a test or qualification program on the part of the buyer.

Application Limitations

WhiteOak Controls, Inc. designs and manufactures its products specifically for use in commercial, industrial and mobile control applications and WhiteOak Controls' products are only warranted for this type of use. WhiteOak Controls' distributors are not authorized to approve the use of any WhiteOak Controls product in any of the following applications:

- Any product that comes under the Federal Highway Safety Act, namely steering or braking systems for passenger-carrying vehicles or on-highway trucks.
- Aircraft or space vehicles.
- Ordnance equipment.
- Any end product that, when sold, comes under the U.S. Nuclear Regulatory Commission rules and regulations.

Specific written approval for any application of WhiteOak Controls products in any of the above named applications should be obtained from WhiteOak Controls, Inc. Consultation with WhiteOak Controls distributors or factory engineers is advised in unusual situations where applicability is questionable.



MVP

Digital Proportional Valve Controller Plug

Physical Description

The MVP is shown at the right. There are two indicator lamps labeled STATUS and OUTPUT. The STATUS lamp will light green whenever power is applied to the unit and is within the specified voltage range. The STATUS light will flash red when a fault has occurred. The type of fault is indicated by the number of successive flashes. It will continue to flash until the command signal has been removed to clear the fault. The yellow lamp labeled OUTPUT provides an indication of the current being supplied to the solenoid outputs.

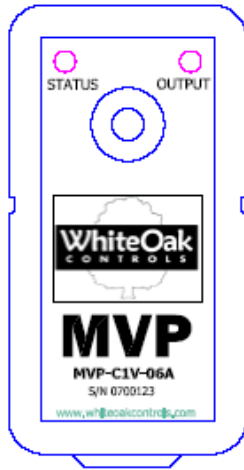

Communication with the MVP takes place through an infrared interface port. The port allows for configuration and monitoring of the operating parameters. The infrared adapter clips onto the MVP aligning with the notches in the sides.

User Interface

The MVP has a number of internal settings which allow each unit to be configured for the application in which it is used. These settings are accessed with a PC running Windows based WhiteOak Terminal software or with the WhiteOak Hand Held Interface

Both methods require the use of the Infrared Adapter which clips onto the MVP.

WhiteOak Terminal provides a convenient interface to the MVP. The program gives the user the ability to view and make changes to the configuration. It also allows the user to store complete configurations in files on the PC. These files can then be recalled to program new units or update existing ones.

The hand held interface is a stand-alone option. Because it is fully self contained, the programmer, cable and adapter are all that is required. This is a good alternative for field installations where a PC might not be convenient.

Configuration

All interface operations are accomplished with the use of 4 buttons. The buttons are Lock, Unlock, Up, and Down. The hand held interface represents these in graphical form as padlocks and arrows. The same symbols are used on the buttons in WhiteOak Terminal and can be activated with the mouse. The program also recognizes menu commands and short-cut keys. The keys used are '/'(lock), '**'(unlock), '+'(up), and '-'(down).

The data displays for both methods are very similar. The hand held interface has a two-line LCD display. The display is represented graphically in WhiteOak Terminal.

The up and down arrows are used to navigate through the parameter list. When either button is pressed the display will be updated with the next parameter in the list. The parameter name will appear on the first line and the associated setting will appear

on the second line. The list is accessed in a circular fashion, stepping down from the last parameter to the first and vice-versa.

There are three types of parameters in the list: fixed; monitor; and variable. Fixed parameters are used to show things such as the module's firmware version number. Fixed parameters do not change. Monitor parameters display things such as output current or system voltage. These parameters are constantly updated when the module is functioning. Variable parameters are those which can be changed by the user in order to configure the module. Examples of this type are operating mode and maximum output current. For convenience, some parameters combine variable and monitor types on one line. This allows the user to set a variable according to the current monitor value.

To change the setting of a variable parameter, the user must press the unlock button to place the system in edit mode. While in edit mode the display will show an asterisk (*) at the beginning of the second line. In edit mode the up and down buttons are used to change the value of the parameter. For parameters which contain both variable and monitor data, the monitor data is shown surrounded by square brackets. Pressing the unlock button again while in edit mode will immediately load the current monitor value into the variable. Once the desired setting is displayed, pressing the lock button will save the parameter and end edit mode.

Parameter List

The following table outlines the parameter list for the MVP. Along with the name of the parameter, the table lists the limits and units for each item.

Parameter	Limits	Units
MVP-Cxx-xxx		Version #
MODE	See Mode Description	Mode #
MINIMUM INPUT	0 to 10.0 (0 to 20.0)	V (mA)
MAXIMUM INPUT	0 to 10.0 (0 to 20.0)	V (mA)
MINIMUM OUTPUT	0 to 600*	mA
MAXIMUM OUTPUT	0 to 600*	mA
DITHER FREQ.	OFF to 300	Hz.
RAMP UP TIME	0.0 to 120.0	Seconds
RAMP DOWN TIME	0.0 to 120.0	Seconds
OUTPUT CURRENT		mA
SUPPLY VOLTAGE		Volts
FAULT STATUS		Fault

*0 to 1.2 A for **-12A** version, 0 to 2.5 A for **-25A** version

WhiteOak MVP - This is the title parameter. The model number of the unit and the firmware version are displayed. The title parameter is fixed.

MODE - There are six modes of operation for the MVP controller. The modes are as follows:

1. Output proportional to input with Enable not used.
2. Output inversely proportional to input with Enable not used.
3. Output proportional to input with Enable.
4. Output inversely proportional to input with Enable.
5. Two speed where Enable provides output at the level set in Minimum Output and Command provides output at the level set in Maximum Output.



MVP

Digital Proportional Valve Controller Plug

- 6. Two speed where Enable provides output at the level set in Maximum Output and Command provides output at the level set in Minimum Output.
The Ramp Up and Ramp Down times apply to all modes.
The Mode parameter is variable.

MINIMUM INPUT - The Minimum Input parameter is used to establish the minimum analog command which results in activation of the output. The value shown in square brackets is the current analog value. The Minimum Input parameter is a combination variable/monitor type.

MAXIMUM INPUT - The Maximum Input parameter is used to establish the maximum analog command for scaling of the output. The output will hold its maximum value for any input equal to or greater than this value. The value shown in square brackets is the current analog value. The Maximum Input parameter is a combination variable/monitor type.

MINIMUM OUTPUT - The Minimum Output parameter represents the minimum current of the output. This is often referred to as the deadband. The value displayed represents the current in milliamps (amps for -12A,-25A). The Minimum Output parameter is variable.

MAXIMUM OUTPUT - The Maximum Output parameter represents the maximum current of the output. This is often referred to as the gain. The value displayed represents the current in milliamps (amps for -12A,-25A). The Maximum Output parameter is variable.

DITHER FREQ. - The Dither Frequency parameter has 11 options for dither control. The choices are Off, 30, 33, 38, 43, 50, 60, 75, 100, 150, and 300 Hz. Dither control provides low frequency modulation which is required in many proportional valve applications. The Dither Frequency parameter is variable.

RAMP UP/DOWN TIME – Ramp Up Time and Ramp Down Time are used to limit the rate of change of the input command signal, and therefore the ramp time of the output. The amount of time required to ramp through the full input range is set by these parameters. When the input command is increasing, the Ramp Up Time is used. When the input command is decreasing, the Ramp Down Time is used. The Ramp Up/Ramp Down Time parameters are variable.

OUTPUT CURRENT - Output Current displays the nominal current being supplied to the output. The Output Current parameter is a monitor type.

SUPPLY VOLTAGE - The Supply Voltage parameter displays the module's power supply voltage. This value is included as an aid to troubleshooting. The Supply Voltage parameter is a monitor type.

FAULT STATUS - The Fault Status parameter displays the current fault code when a fault exists. The three possible faults are 1-Over Current, 2-Open Output, and 3-Output Shorted. The Fault Status parameter is a monitor type. In addition to the on-screen fault status, the STATUS light will flash red indicating a problem. The light will flash a number of times periodically corresponding to the above fault codes.

Ordering Information

The following is a break down of the MVP part numbering system:

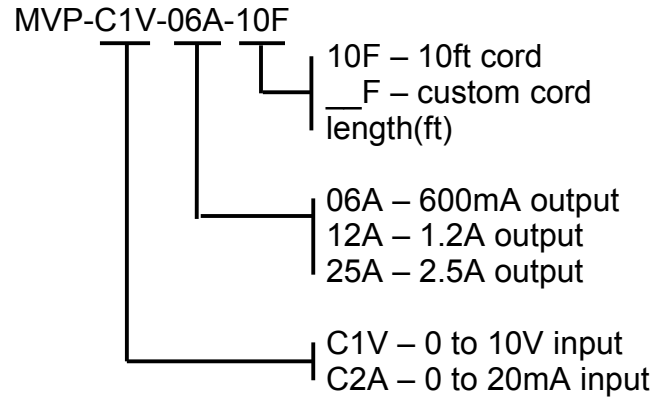

Wiring

Wire functions are listed in the table below. Following the table are wiring examples for various modes of operation.

Terminal	Function
BROWN	+V Supply
BLUE	Supply Common
BLACK	Command Input
WHITE	Enable Input
RED	+5V Reference*
GRN/YEL	Connector ground

Single Solenoid Joystick Control (MVP-C1V-xxx)

The MVP can be controlled with a joystick or potentiometer as shown. This configuration uses Mode 3 with the Enable signal or Mode 1 with no Enable line.

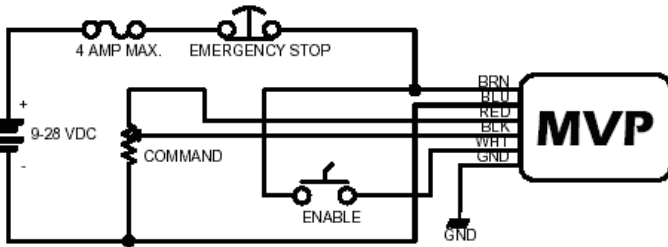

Single Solenoid PLC Control (MVP-C1V-xxx)

The MVP can be controlled with PLC as shown. This configuration uses Mode 3 with the Enable signal or Mode 1 with no Enable line.

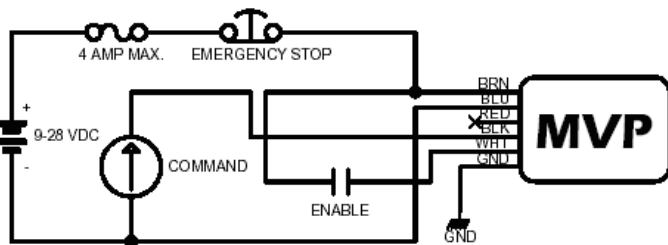

Double Solenoid (MVP-C1V-xxx)

Two MVPs can be driven by one signal for double solenoid operation as shown in the following diagram. One should be set to Mode 1 or 3 while the other is set Mode 2 or 4. The minimum input parameters for the two should be set such that both units will not be active with the same input signal.

NOTE: Loss of Command signal in this configuration will result in maximum output to one solenoid. Care must be taken to avoid injury or damage in the event of a signal failure!

Double Solenoid (MVP-C1V-xxx)

Two MVPs can be driven by one signal for double solenoid operation as shown in the following diagram. This configuration uses a selector switch to determine which solenoid is activate and a single potentiometer to determine output level. This configuration corresponds to Mode 1 or Mode 3.

Single Solenoid 2-Speed Control (MVP-C1V-xxx)

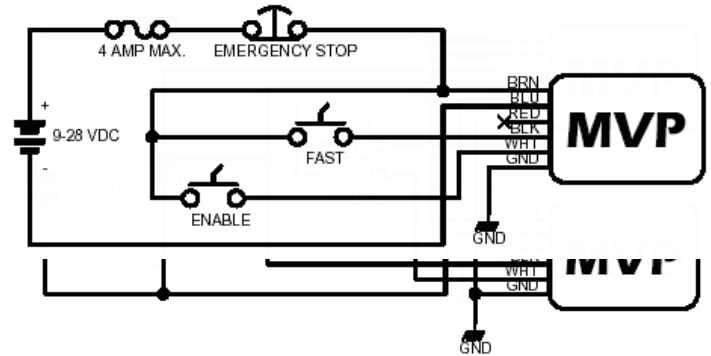

The MVP can be configured for 2-speed mode as shown. In this arrangement the Enable signal allows minimum output and the Command signal allows maximum output. This configuration corresponds to Mode 5.

Single Solenoid 2-Speed Control (MVP-C1V-xxx)

The MVP can be configured for 2-speed mode as shown. In this arrangement the Enable signal allows maximum output and the Command signal limits output to the minimum setting. This configuration corresponds to Mode 6.

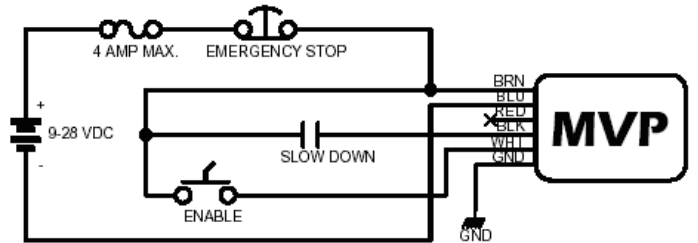

***NOTE: If the +5V Reference is not used it must be isolated to prevent shorting to other wires. Failure to do so can result in damage to the controller.**