



ProValve 100

Electronic Proportional Valve Controller

The ProValve 100 is an electronic control module for use with proportional solenoid valves. The module will provide current to the solenoids of the valve in response to various types of signals provided by the control system. Indicators on the front of the module provide an overview of the operating status. System configuration is accomplished through a convenient remote terminal. All settings are stored in permanent memory within the unit. The unit is housed in an attractive, compact enclosure.

- Various control input options including analog, digital and mixed
- Easily configured using WhiteOak software or hand held interface
- Front panel indicators for Power, Output Current and System Faults
- DIN rail mounting and removable terminals for easy wiring and maintenance
- Selectable dither frequency up to 244 Hz
- Adjustable current limited output with short circuit protection
- Reference voltage outputs for potentiometer/joystick controls
- Independently adjustable gain and deadband for input and output
- Independent digital ramp times and analog slew rate limiting
- Microprocessor controlled for consistent, reliable performance



Operating Specifications:

Supply Voltage	12 to 30VDC
Supply Current	$I_{SOL} + 50mA$ (Additional current is required when the hand held interface is attached.)
Output Current	Standard: 2.5A MAX. -L: 500mA MAX. -N: 250mA MAX.
Solenoid Resistance	Standard: 2 Ω MIN. -L,-N: 10 Ω MIN.
Reference Voltages	-10V, +10V @ 2mA
Dither Settings	Off, 35, 41, 49, 61, 81, 122, 244 Hz
Two-speed Ramp Time	0.10 to 16.96 seconds
Analog Slew Time	0.1 to 30.0 seconds
Analog Input Range	0 to 10V, -10V to +10V, 0 to 5V, -5V to +5V, 0-20mA, 4-20mA
Analog Input Impedance	$INV_R > 100k\Omega$, $INI_R = 500$ Ohms
Digital Input Range	-24 12 to 30 VDC Positive or Negative Logic -115 100 to 130 VAC -230 210 to 250 VAC
Digital Input Impedance	-24 3.3k Ω -115 33k Ω -230 75k Ω
Operating Temperature Range	0° to 70° C

WARRANTY INFORMATION, PERFORMANCE ASSURANCE, AND APPLICATION LIMITATIONS

Limited Warranty

WhiteOak Controls, Inc. warrants its products free from defects in material, workmanship, and design for a period of one year after installation, provided the installation date is less than one year after manufacture. In no instance is there any warranty of fitness for a particular use and WhiteOak Controls, Inc. cannot and does not accept responsibility of any type for any of its products that have been subjected to improper installation, improper application, negligence, tampering, or abuse, or which have been repaired or altered outside of the WhiteOak Controls factory. WhiteOak Controls' liability under this warranty shall extend only to replacement or correction, f.o.b. our factory, of any defective part or product determined by inspection as not conforming to this warranty. We make no other warranties, expressed or implied, and are not responsible for any consequential damages resulting from use by any buyer or user, our liability being limited to the value of product sold or obligation to replace a defective part.

Performance Assurance

All WhiteOak Controls products are individually tested at the factory to perform as indicated in all applicable sales and technical documentation. However, assurance of suitability of all WhiteOak Controls products in the buyer's application is the responsibility of the buyer. Such assurance would typically include the manufacture of a prototype followed by a test or qualification program on the part of the buyer.

Application Limitations

WhiteOak Controls, Inc. designs and manufactures its products specifically for use in commercial, industrial and mobile control applications and WhiteOak Controls' products are only warranted for this type of use. WhiteOak Controls' distributors are not authorized to approve the use of any WhiteOak Controls product in any of the following applications:

- Any product that comes under the Federal Highway Safety Act, namely steering or braking systems for passenger-carrying vehicles or on-highway trucks.
- Aircraft or space vehicles.
- Ordnance equipment.
- Any end product that, when sold, comes under the U.S. Nuclear Regulatory Commission rules and regulations.

Specific written approval for any application of WhiteOak Controls products in any of the above named applications should be obtained from WhiteOak Controls, Inc. Consultation with WhiteOak Controls distributors or factory engineers is advised in unusual situations where applicability is questionable.



ProValve 100

Electronic Proportional Valve Controller

Physical Description

The ProValve 100 faceplate is shown at the right. The boxed numbers represent the relative terminal positions. A label on the side of the module provides a list of terminal functions.

There are four indicator lamps. The green lamp labeled POWER is lit whenever power is applied to the unit. The yellow lamps labeled OUTPUT A and OUTPUT B provide an indication of the current being supplied to the solenoid outputs. The red lamp marked FAULT displays the over current protection status. This lamp will light as the result of a short circuit, open circuit, over current fault or low reference voltage. It will remain lit until the command signal has been removed to clear the fault.

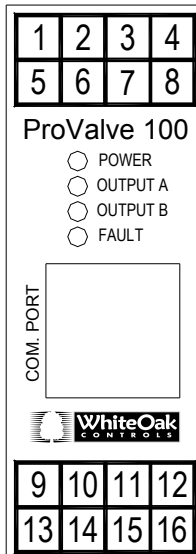

The final item on the front panel is the communications port. The Hand Held Interface or a PC interface cable may be connected to this port. The port allows for configuration and monitoring of the operating parameters.

User Interface

The ProValve 100 has a number of internal settings which allow each unit to be configured for the application in which it is used. These settings are accessed in one of three ways:

- A PC running proprietary Windows based software
- The Hand Held Interface
- A PC running terminal emulation software

All three methods use the communication port on the front of the module. Connection to a PC requires a RJ-11 to DB9 converter (see *Wiring* for details).

WhiteOak Controls' Windows based software provides a convenient interface to the ProValve 100. The program gives the user the ability to view and make changes to the configuration. It also allows the user to store complete configurations in files on the PC. These files can then be recalled to program new units or update existing ones.

The hand held interface is a stand-alone option. Because it is powered from the serial port and fully self contained, the programmer and cable are all that is required. This is a good alternative for field installations where a PC might not be convenient.

The final option is a PC running terminal emulation software. The ProValve 100 can be accessed through most terminal emulation programs such as HyperTerminal or Procomm. Refer to the following table for communications settings.

Baud Rate	2400
Data Bits	8
Parity	None
Stop Bits	1
Flow Control	None
Local Echo	Off
Append Line Feeds on Incoming Line Ends	Off

Configuration

All interface operations are accomplished with the use of 4 buttons in each of the three methods. The buttons are Lock, Unlock, Up, and Down. The hand held interface represents these in graphical form as padlocks and arrows. The same symbols are used on the buttons in the software package and can be activated with the mouse. The program also recognizes menu commands and short-cut keys. The keys used are '/'(lock), '*'(unlock), '+'(up), and '-'(down). These same keys are used with terminal emulation software to access the functions.

The data displays for the three methods are very similar. The hand held interface has a two-line LCD display. The software has a graphical representation of that display. When using terminal emulation software, two lines of data will be displayed in the terminal window.

The up and down arrows are used to navigate through the parameter list. When either button is pressed the display will be updated with the next parameter in the list. The parameter name will appear on the first line and the associated setting will appear on the second line. The list is accessed in a circular fashion, stepping down from the last parameter to the first and vice-versa.

There are three types of parameters in the list: fixed; monitor; and variable. Fixed parameters are used to show things such as the module's firmware version number. Fixed parameters do not change. Monitor parameters display things such as output current or system voltage. These parameters are constantly updated when the module is functioning. Variable parameters are those which can be changed by the user in order to configure the module. Examples of this type are operating mode and maximum output current. For convenience, some parameters combine variable and monitor types on one line. This allows the user to set a variable according to the current monitor value.

To change the setting of a variable parameter, the user must press the unlock button to place the system in edit mode. While in edit mode the display will show an asterisk (*) at the beginning of the second line. In edit mode the up and down buttons are used to change the value of the parameter. For parameters which contain both variable and monitor data, the monitor data is shown surrounded by square brackets. Pressing the unlock button again while in edit mode will immediately load the current monitor value into the variable.



ProValve 100

Electronic Proportional Valve Controller

Once the desired setting is displayed, pressing the lock button will save the parameter and end edit mode.

Parameter List

The following table outlines the parameter list for the ProValve 100. Along with the name of the parameter, the table lists the limits and units for each item.

Parameter	Limits	Units
PROVALVE 100		Version #
MODE AI D1 D2 D3	0 to 7	Mode #
A MINIMUM INPUT	-100.0 to 100.0	%
A MAXIMUM INPUT	-100.0 to 100.0	%
A MINIMUM OUTPUT	0.01 to 2.50*	Amps
A LOW/OVR OUTPUT	0.01 to 2.50*	Amps
A MAXIMUM OUTPUT	0.01 to 2.50*	Amps
B MINIMUM INPUT	-100.0 to 100.0	%
B MAXIMUM INPUT	-100.0 to 100.0	%
B MINIMUM OUTPUT	0.01 to 2.50*	Amps
B LOW/OVR OUTPUT	0.01 to 2.50*	Amps
B MAXIMUM OUTPUT	0.01 to 2.50*	Amps
DITHER FREQ.	OFF to 244	Hz.
INPUT SLEW TIME	0.0 to 30.0	Seconds
RAMP UP LOW	0.10 to 16.96	Seconds
RAMP UP HIGH	0.10 to 16.96	Seconds
RAMP DOWN HIGH	0.10 to 16.96	Seconds
RAMP DOWN LOW	0.10 to 16.96	Seconds
OUTPUT CURRENT		Amps
SUPPLY VOLTAGE		Volts
FAULT STATUS		Fault

*0 to 500 mA for -L version, 0 to 250mA for -N version

PROVALVE 100 - This is the title parameter. The name of the unit and the firmware version are displayed. The title parameter is fixed.

MODE AI D1 D2 D3 - The Mode parameter sets up the functional operation of the module. There are 8 modes to choose from. The AI, D1, D2, and D3 represent the analog and digital inputs. The text below each of these corresponds to the function of that input in a particular mode. This provides a quick reference to the function of each mode of operation. Details of the mode parameter are discussed in the Modes of Operation section. The Mode parameter is variable.

A MINIMUM INPUT - The A Minimum Input parameter is used to establish the minimum analog command which results in activation of the A output. The value displayed represents the sign of the input signal and the percentage of the maximum input. The value shown in square brackets is the current analog value. The A Minimum Input parameter is a combination variable/monitor type.

A MAXIMUM INPUT - The A Maximum Input parameter is used to establish the maximum analog command for scaling of the A output. The output will hold its

maximum value for any input equal to or greater than this value. The value displayed represents the sign of the input signal and the percentage of the maximum input. The value shown in square brackets is the current analog value. The A Minimum Input parameter is a combination variable/monitor type.

A MINIMUM OUTPUT - The A Minimum Output parameter represents the minimum current of the A output. This is often referred to as the deadband. The value displayed represents the current in amps. The A Minimum Output parameter is variable.

A LOW/OVR OUTPUT - The A Low/Ovr Output parameter represents the current supplied to the A output when low speed is chosen in digital input mode. It also represents the current used for the forward override command in analog modes. The value displayed represents the current in amps. The A Low/Ovr Output parameter is variable.

A MAXIMUM OUTPUT - The A Maximum Output parameter represents the maximum current of the A output. This is often referred to as the gain. The value displayed represents the current in amps. The A Maximum Output parameter is variable.

B MINIMUM INPUT - The B Minimum Input parameter is used to establish the minimum analog command which results in activation of the B output. The value displayed represents the sign of the input signal and the percentage of the maximum input. The value shown in square brackets is the current analog value. The B input/output parameters are only used with modes where the analog input determines direction. Because these parameters represent the "negative" part of the input range, the B Minimum Input will be greater than the B Maximum Input. The B Minimum Input parameter is a combination variable/monitor type.

B MAXIMUM INPUT - The B Maximum Input parameter is used to establish the maximum analog command for scaling of the B output. The output will hold its maximum value for any input equal to or less than this value. The value displayed represents the sign of the input signal and the percentage of the maximum input. The value shown in square brackets is the current analog value. The B Minimum Input parameter is a combination variable/monitor type.

B MINIMUM OUTPUT - The B Minimum Output parameter represents the minimum current of the B output. This is often referred to as the deadband. The value displayed represents the current in amps. The B Minimum Output parameter is variable.

B LOW/OVR OUTPUT - The B Low/Ovr Output parameter represents the current supplied to the B output when low speed is chosen in digital input mode. It also represents the current used for the reverse override



ProValve 100

Electronic Proportional Valve Controller

command in analog modes. The value displayed represents the current in amps. The B Low/Ovr Output parameter is variable.

B MAXIMUM OUTPUT - The B Maximum Output parameter represents the maximum current of the B output. This is often referred to as the gain. The value displayed represents the current in amps. The B Maximum Output parameter is variable.

DITHER FREQ. - The Dither Frequency parameter has 8 options for dither control. The choices are Off, 35, 41, 49, 61, 81, 122, and 244 Hz. Dither control provides low frequency modulation which is required in some proportional valve applications. The Dither Frequency parameter is variable.

INPUT SLEW TIME - Input Slew Time is used to limit the rate of change of the input command signal. The amount of time required to ramp from 0 to 100% is set by this parameter. The same time is used when ramping up or down. The Input Slew Time parameter is variable.

RAMP UP LOW - Ramp Up Low is the amount of time used to ramp the output from off to low speed in seconds. This parameter applies only to two-speed modes. The Ramp Up Low parameter is variable.

RAMP UP HIGH - Ramp Up High is the amount of time used to ramp the output from low speed to high speed in seconds. This parameter applies only to two-speed modes. The Ramp Up High parameter is variable.

RAMP DOWN HIGH - Ramp Down High is the amount of time used to ramp the output from high speed to low speed in seconds. This parameter applies only to two-speed modes. The Ramp Down High parameter is variable.

RAMP DOWN LOW - Ramp Down Low is the amount of time used to ramp the output from low speed to off in seconds. This parameter applies only to two-speed modes. The Ramp Down Low parameter is variable.

OUTPUT CURRENT - Output Current displays the nominal current being supplied to either of the outputs. The Output Current parameter is a monitor type.

SUPPLY VOLTAGE - The Supply Voltage parameter displays the module's power supply voltage. This value may vary slightly from measured value but is included to aid in troubleshooting. The Supply Voltage parameter is a monitor type.

FAULT STATUS - The Fault Status parameter displays the current fault code when a fault exists. The four possible faults are Over Current, Open Output, Voltage Drop and Low -10V Supply. The Fault Status parameter is a monitor type.



ProValve 100

Electronic Proportional Valve Controller

Modes of Operation

The ProValve 100 has 8 modes of operation. The modes represent a combination of options including digital and analog input, enable control, and override functions. Each mode is displayed with a quick reference of each input function. The modes and functions are shown in the following table:

Mode	AIN	DIN1	DIN2	DIN3
0 SD -- OF OR	Speed/Direction	Not Used	Forward Override	Reverse Override
1 DR -- -- HS	Direction	Not Used	Not Used	High Speed
2 SP FW RV --	Speed	Forward Enable	Reverse Enable	Not Used
3 -- FW RV HS	Not Used	Forward Enable	Reverse Enable	High Speed
4 SD EN OF OR	Speed/Direction	Enable	Forward Override	Reverse Override
5 DR EN -- HS	Direction	Enable	Not Used	High Speed
6 SP EN RV --	Speed	Enable	Reverse	Not Used
7 -- EN RV HS	Not Used	Enable	Reverse	High Speed

Mode 0 - In Mode 0 both speed and direction are controlled by the analog input. The full -10V to +10V analog input range is used. Any signal in the A Input range results in activation of the A Output. Any signal in the B Input range results in activation of the B Output. The speed is set according to the signal magnitude relative to the range. Digital inputs provide forward and reverse overrides.

Mode 1 - In Mode 1 the direction is controlled by the analog input. The full -10V to +10V analog input range is used. Any signal in the A Input range results in activation of the A Output. Any signal in the B Input range results in activation of the B Output. When the high speed input (DIN3) is off, the speed is set to the minimum output value. When the high speed input (DIN3) is on, the speed is set to the maximum output value.

Mode 2 - In Mode 2 the speed is controlled by the analog input. The full -10V to +10V analog input range can be used. The speed is set according to the signal magnitude relative to the A range settings. Digital inputs enable output in the forward and reverse directions.

Mode 3 - In Mode 3 both speed and direction are controlled by digital inputs. Digital inputs DIN1 and DIN2 enable output in the forward and reverse directions, respectfully. When forward or reverse are enabled, the speed is determined by DIN3. When DIN3 is off, the speed is set to the low speed output value. When DIN3 is on, the speed is set to the maximum output value.

Mode 4 - In Mode 4 both speed and direction are controlled by the analog input. The full -10V to +10V analog input range is used. The enable input (DIN1) must be on for any output to occur. When enabled, any signal in the A Input range results in activation of the A Output. Likewise, any signal in the B Input range results in activation of the B Output. The speed is set according

to the signal magnitude relative to the range. Digital inputs provide forward and reverse overrides.

Mode 5 - In Mode 5 the direction is controlled by the analog input. The full -10V to +10V analog input range is used. The enable input (DIN1) must be on for any output to occur. When enabled, any signal in the A Input range results in activation of the A Output. Likewise, any signal in the B Input range results in activation of the B Output. When the high speed input (DIN3) is off, the speed is set to the minimum output value. When the high speed input (DIN3) is on, the speed is set to the maximum output value.

Mode 6 - In Mode 6 the speed is controlled by the analog input. The full -10V to +10V analog input range can be used. When enabled, the speed is set according to the signal magnitude relative to the A range settings. Activation of both enable (DIN1) and reverse (DIN2) are required for reverse output.

Mode 7 - In Mode 7 both speed and direction are controlled by digital inputs. The enable input (DIN1) must be on for any output to occur. Digital input DIN2 is used for reverse operation. When the unit is enabled, the speed is determined by DIN3. When DIN3 is off, the speed is set to the low speed output value. When DIN3 is on, the speed is set to the maximum output value.



ProValve 100

Electronic Proportional Valve Controller

Wiring

Terminal connections are listed in the table below. Following the table are wiring examples for various modes of operation.

Terminal	Name	Function
1	+V Supply	+24V
2	Supply Common	COM
3	+10V Reference	+10V OUT
4	-10V Reference	-10V OUT
5	Signal Input +	IN+
6	Signal Voltage Input -	INV-
7	Frame Ground	GND
8	Signal Current Input -	INI-
9	Output A	OUT A
10	Supply Common	COM
11	Output B	OUT B
12	Supply Common	COM
13	Digital Input Common	DCOM
14	Digital Input #1	DIN1
15	Digital Input #2	DIN2
16	Digital Input #3	DIN3

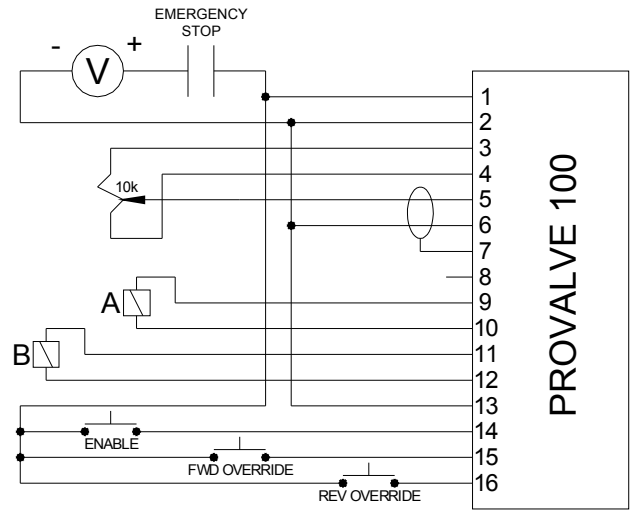

Analog Speed/Direction

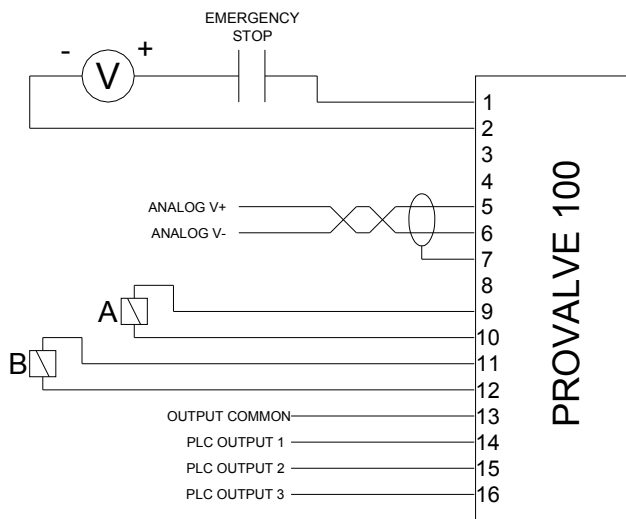

PLC Interface

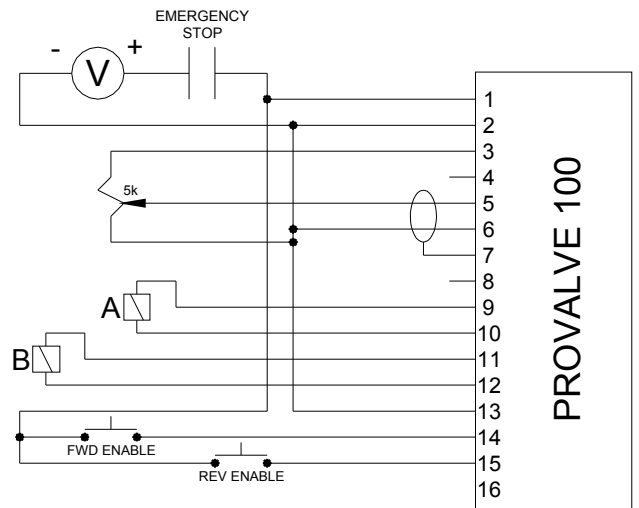

Analog Speed/Digital Direction

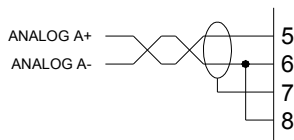

Current Input



ProValve 100

Electronic Proportional Valve Controller

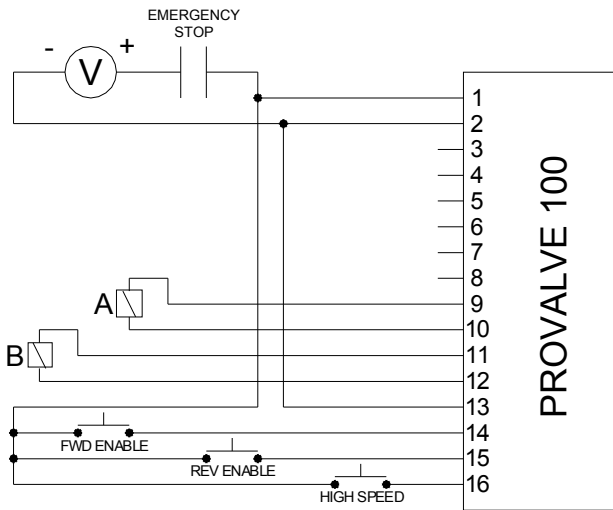

Digital Speed/Direction

Ordering Information

The following part numbers should be used when ordering the ProValve 100:

PV100-XX-X

- Blank** – 0 to 2.5 Amp output
- L** – 0 to 500 mA output
- N** – 0 to 250 mA output

- 24** – 24VDC digital inputs
- 115** – 115VAC digital inputs
- 230** – 230VAC digital inputs

The following diagram shows the RJ-11 to DB9 converter pinout:

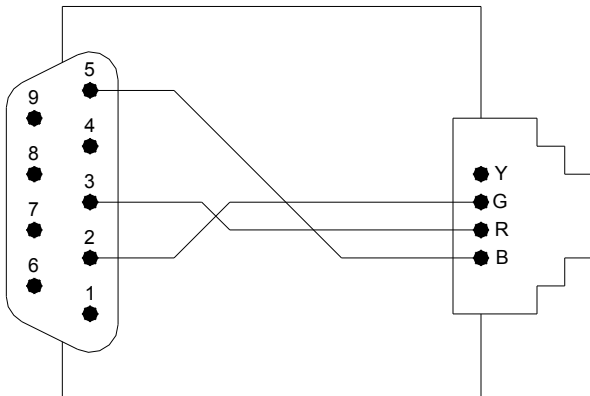

DB9 TO RJ-11 CONVERTER
(VIEWED FROM OUTSIDE)